

MDC-200



MDC-200

This manual provides specifications for the MDC-200 linear CCD scan engine with built-in decoder.

Specifications Manual

All information subject to change without notice.

Document History

Model Number:	MDC-200	Specification Number:	SS13074
Edition:	2	Original Spec Number:	SS13073
Date:	2015/01/19		

Copyright 2014 Opticon. All rights reserved.

This manual may not, in whole or in part, be copied, photocopied, reproduced, translated or converted to any electronic or machine readable form without prior written consent of Opticon.

Limited Warranty and Disclaimers

PLEASE READ THIS MANUAL CAREFULLY BEFORE INSTALLING OR USING THE PRODUCT.

Serial Number

A serial number appears on all Opticon products. This official registration number is directly related to the device purchased. Do not remove the serial number from your Opticon device. Removing the serial number voids the warranty.

Warranty

Unless otherwise agreed in a written contract, all Opticon products are warranted against defects in materials and workmanship for two years after purchase. Opticon will repair or, at its option, replace products that are defective in materials or workmanship with proper use during the warranty period. Opticon is not liable for damages caused by modifications made by a customer. In such cases, standard repair charges will apply. If a product is returned under warranty and no defect is found, standard repair charges will apply. Opticon assumes no liability for any direct, indirect, consequential or incidental damages arising out of use or inability to use both the hardware and software, even if Opticon has been informed about the possibility of such damages.

Packaging

The packing materials are recyclable. We recommend that you save all packing material to use should you need to transport your scanner or send it for service. Damage caused by improper packaging during shipment is not covered by the warranty.

Trademarks

Trademarks used are the property of their respective owners.

Opticon Inc. and Opticon Sensors Europe B.V. are wholly owned subsidiaries of OPTOELECTRONICS Co., Ltd., 12-17, Tsukagoshi 4-chome, Warabi-shi, Saitama, Japan 335-0002. TEL +81-(0) 48-446-1183; FAX +81-(0) 48-446-1184

SUPPORT

USA

Phone: 800-636-0090

Email: support@opticonusa.com

Web: www.opticonusa.com

Europe

Email: support@opticon.com

Web: www.opticon.com

Revision History

Specification No. : SS13074
Product name : MDC-200

Edition	Date	Page	Section	Description of Changes
1st	2014/09/10	-	-	Initial release
	2014/10/24	3	5	Revised the statement of Low Power mode
2nd	2015/01/19	1	2	Added examples of LCD screens

Contents

1. Abstract	1
2. Overview	1
3. Physical Features	1
3.1. Dimensions	1
3.2. Weight	1
4. Electrical Specifications	2
5. Power Mode Transition	3
6. Interface Specifications	4
7. Optical Specifications	5
7.1. General Factors	5
7.2. Optical Clear Zone for Decoding	5
7.3. Recommended Installation Condition of Exit Window	6
7.4. Optical Clear Area of Exit Window	7
8. Technical Specifications	8
8.1. Depth of Field	8
8.2. Pitch, Skew and Tilt	9
8.3. Curvature	9
9. Environmental Specifications	10
9.1. Temperature	10
9.2. Humidity	10
9.3. Ambient Light Immunity	10
9.4. Electrostatic Noise	10
9.5. Vibration Strength	10
9.6. Drop Impact Strength	10
10. Regulatory Compliance	11
11. RoHS	11
12. Reliability	11
13. Precautions	11
14. Packaging Specifications	12
14.1. Packaging	12
14.2. Package Size	14
15. Serial Label	14
16. Mechanical Drawing	15

1. Abstract

This manual provides specifications for the MDC-200 linear CCD scan engine with built-in decoder.

2. Overview

The MDC-200 is a compact barcode scan engine that can be installed in various handheld products such as a portable device. The use of short wavelength red LED illumination enhances the visibility when aiming at a barcode. The MDC-200 has a built-in decoder that enables this scan engine to decode the bar codes after scanning and output the information via its serial communication interface. The MDC-200 is RoHS compliant.

Features

- MDC-200 is only 7.5 mm in height, allowing low profile installation in, for example smart-phones and data collectors.
- MDC-200's high definition glass lens ensures reliable performance in various conditions.
- Its strong glass-fiber reinforced polycarbonate body is resistant to mechanical shocks, enabling use from general home environment to hard field applications.
- Its 50 degree scan angle is larger than that of any laser scan engine in equivalent class, enabling it to read high capacity barcode in space-limited applications.
- MDC-200's patented adaptive illumination technology allows it to automatically read barcodes either on paper or on LCD screens such as mobile phone / tablet / and PC monitor, while keeping the power consumption very low.
- MDC-200 features both RS-232C and USB interfaces.

3. Physical Features

3.1. Dimensions

22.8 × 15.0 × 7.5 (WDH mm)

3.2. Weight

2.6 g

4. Electrical Specifications

Absolute Maximum Ratings

Item	Symbol	Rated Value	Unit
Power Supply Voltage(Vcc to GND)	Vcc	3.9	V
Input Voltage	V1	-0.3 ~ Vcc +0.3	V

Electrical Characteristics VCC = 3.3 V, Ta = 25 °C

Item	Symbol	Conditions	Min	Typ	Max	Unit
Operating Voltage	V _{cc}		3.0	—	3.6	V
Operating Current	I _{OP}	READ State	—	110	120	mA
Idle Current	I _{IDL}	IDLE State	—	18	25	mA
Sleep Current	I _{SLP}	SLEEP State	-	100	-	uA
Peak Inrush Current	I _{PEEK}		—	150	200	mA
Input Voltage	High	V _{IH}	V _{CC} ×0.8	—	—	V
	Low	V _{IL}	—	—	V _{CC} ×0.2	V
Output Voltage	High	V _{OH}	I _{OH} =-1mA	V _{CC} -0.5	—	V
	Low	V _{OL}	I _{OL} =1.0mA	—	—	0.5
Input Current	I _{IN}	V _{IN} =Vcc V _{IN} =0V	—	—	1.0	uA

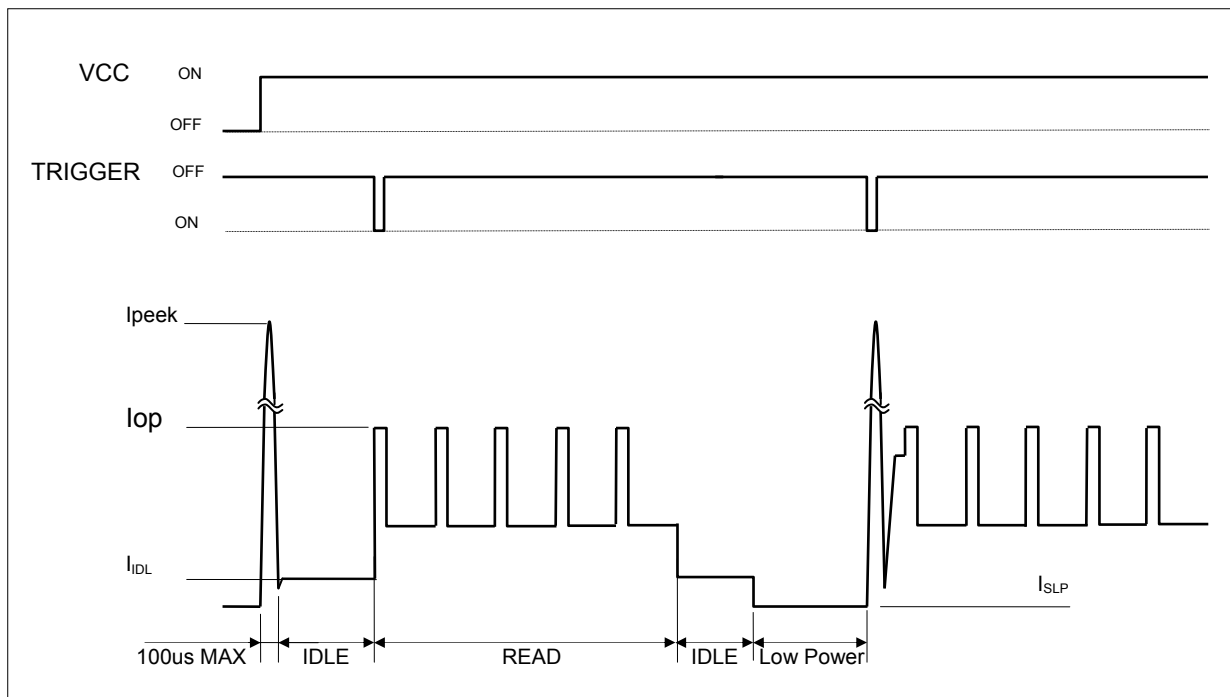

Figure 1: Current Waveform

5. Power Mode Transition

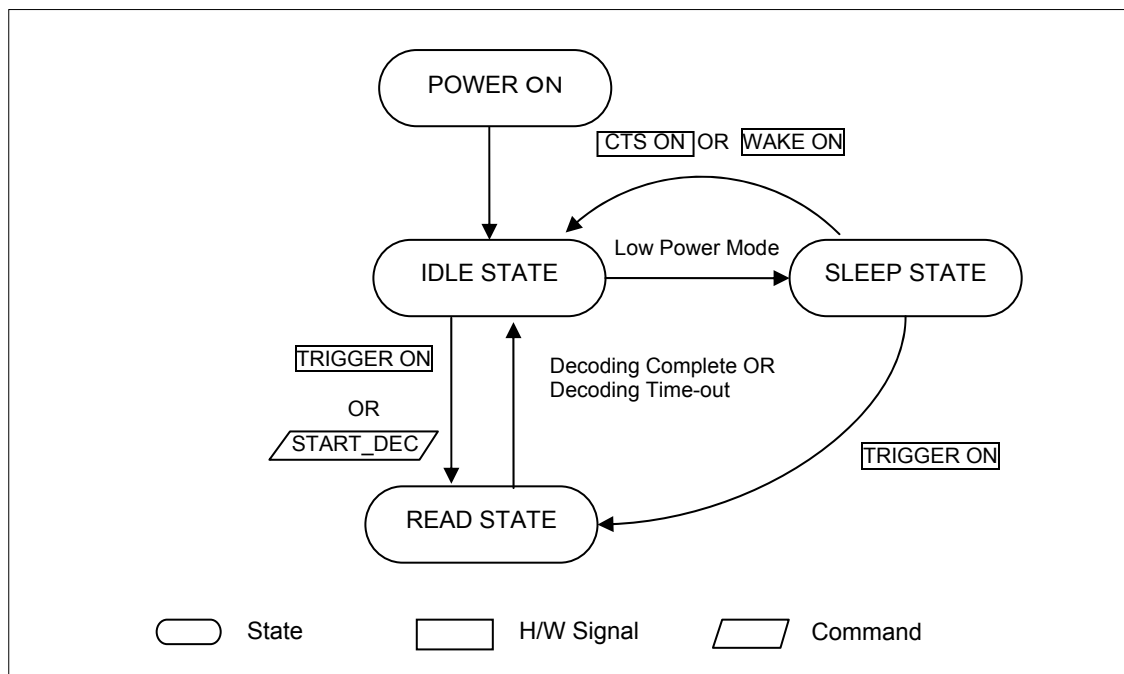

Figure 2: Power Mode Transition

* Low Power mode is ONLY available when using RS-232C interface.

- When “Low Power” mode is enabled, the MDC-200 automatically enters “SLEEP” state from “Power-ON”.
- When moving to “IDLE” state by “CTS ON” or “WAKE ON” from “SLEEP” state, MDC-200 goes back to “SLEEP” state in two seconds if no event occurs to move to other states.

Universal ID	Description	Default
Z5	Disable Low Power mode	Y
Z6	Enable Low Power mode	

6. Interface Specifications

Connector used: IRISO Electronics Co.,LTD."IMSA-9681S-12",
12-pin, 0.5 mm pitch, FFC connector, bottom contact type (gold-plated)

Signal	Pin No.	I/O	Functions
Trigger	1	I	Trigger input, CMOS logic level: Low = Trigger
Wake	2	I	Wakeup input, CMOS logic level: Low = Wake
Decode LED	3	O	LED output, CMOS logic level: Low = LED On
Buzzer	4	O	Buzzer control pulse output, CMOS logic level: Low = Buzzer On
Power Down	5	O	Power down output, CMOS logic level: High = Low Power state
RTS	6	O	Request to send, CMOS logic level
CTS/USB+	7	I/O	Clear to send, CMOS logic level / USB + data signal
Txd	8	O	Serial data output, CMOS logic level
Rxd/USB-	9	I/O	Serial data input, CMOS logic level / USB- data signal
GND	10	—	Ground
VDD	11	I	Power supply: DC 3.0V ~ 3.6V
Boot	12	I	Start signal input, CMOS logic level : High = normal operation

7. Optical Specifications

7.1. General Factors

Item		Characteristics		Unit
Illumination		Amber LED		—
Peak wavelength		624		nm
Scan rate		300 Maximum		scans
FOV	Horizontal	50		deg
	Vertical	±0.25	TYP	deg
		±(1.3 ~ 1.8)	MAX	

7.2. Optical Clear Zone for Decoding

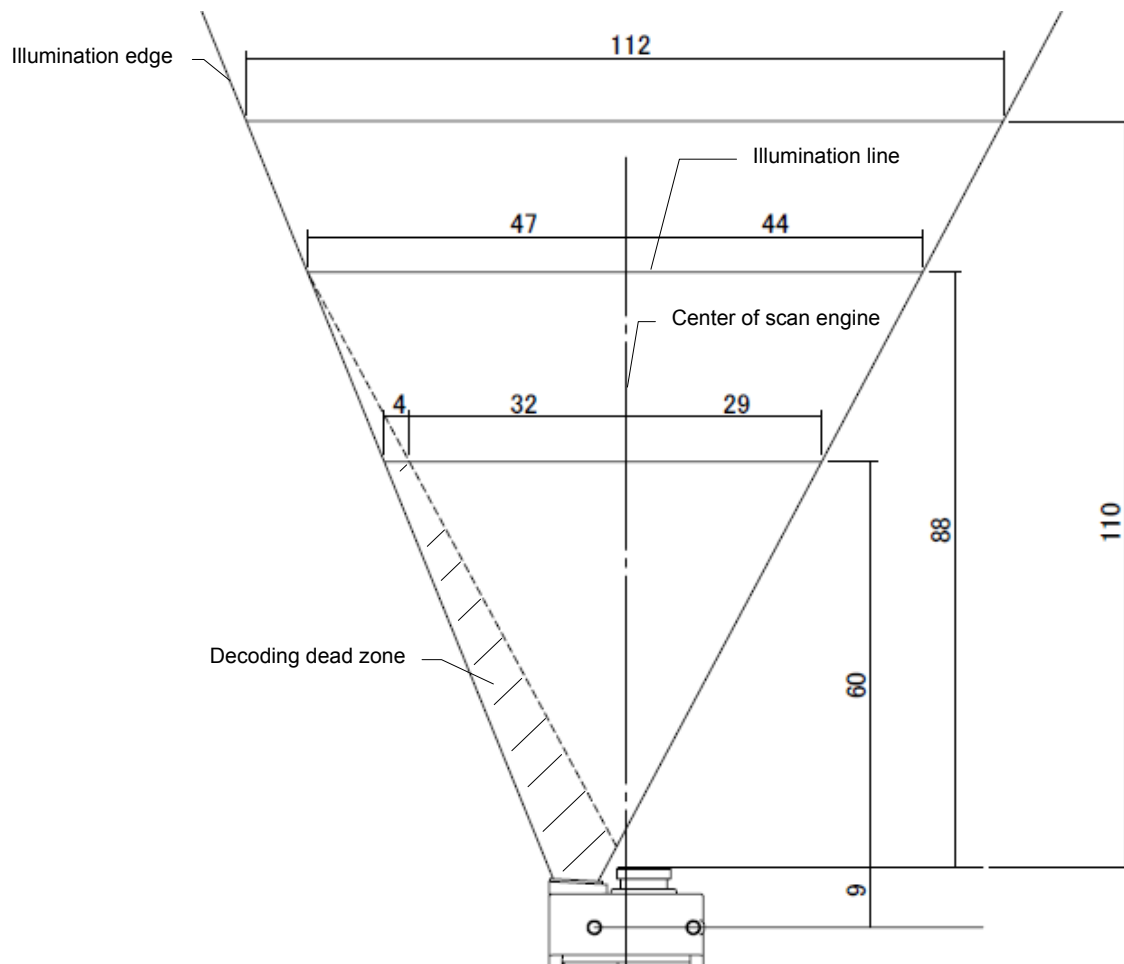
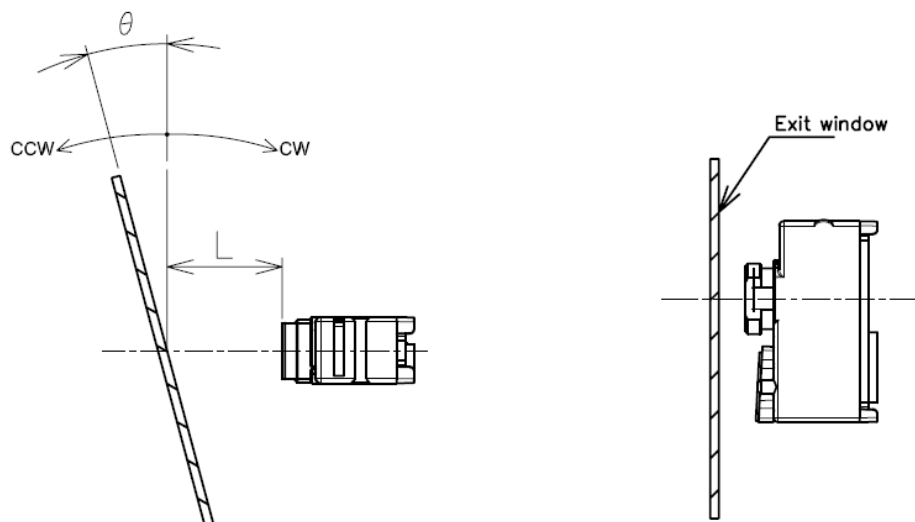

Figure 3: Optical Clear Zone for Decoding

- 1: Illumination line except the dead zone (out of the FOV of imaging lens) is defined as optical clear path, where the MDC-200 is able to decode.
- 2: Illumination edge is defined by 90% peak luminance of illumination line.

7.3. Recommended Installation Condition of Exit Window

The material of exit window is recommended to be transparent colorless PMMA plate with its thickness is less than 1.0mm. The plate is recommended with optical flatness and with optical anti-reflective coating on both surfaces. To remove the reflected LED illumination rays from the exit window, the following condition should be satisfied.



L(mm)	0.5	1.0	1.5	2.0	2.5	3.0	3.5	4.0	4.5	5.0	6.0	7.0	8.0	9.0	≥10
θ_{cw} (deg)	0.0	0.0	0.0	≥15 ≤25	≥15 ≤30	≥15 ≤35	≥15 ≤35	≥15 ≤35	≥15 ≤35	≥15 ≤35	≥15 ≤35	≥15 ≤35	≥15 ≤35	≥15 ≤35	≥15 ≤35
θ_{ccw} (deg)	0.0	0.0	0.0	≥15 ≤25	≥15 ≤30	≥15 ≤35	≥15 ≤35	≥15 ≤35	≥15 ≤35	≥15 ≤35	≥15 ≤35	≥15 ≤35	≥15 ≤35	≥15 ≤35	≥15 ≤35

Figure 4: Recommended Installation Condition

<Test condition>

Exit window : 1.0mm thickness PMMA plate without anti-reflect coat

Ambient light : 300lux, neutral white fluorescent lamp, no other light source and no other reflective object in the test environment

Recommending conditions: L < 1.0 mm, θ = 0.0 deg.

7.4. Optical Clear Area of Exit Window

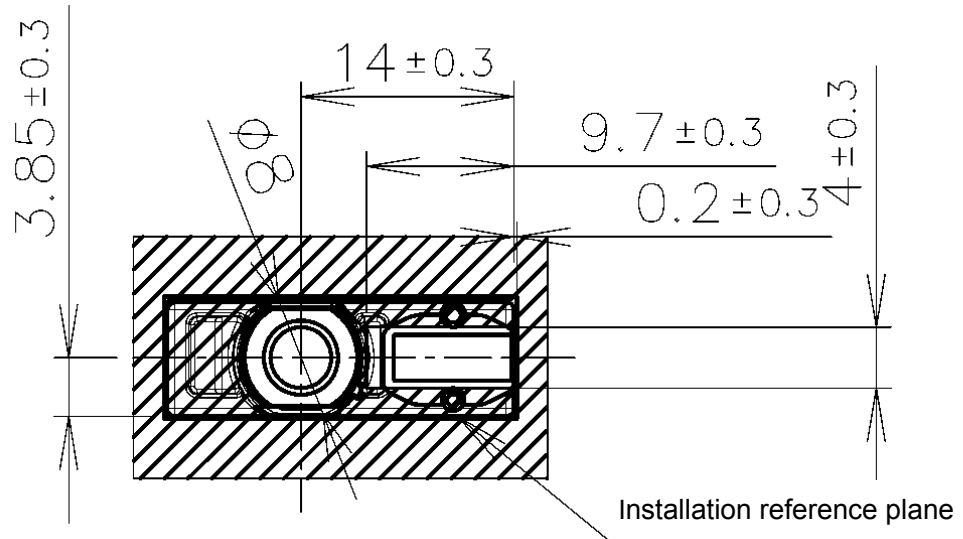

Figure 5: Optical Clear Area of Exit Window

From front view of the scan engine, the non-shaded area indicates the optical clear area. It is recommended to coat the shaded area matt-black. The dimension of the shaded area is based on the condition where the exit window is parallel located at 1 mm distance to the tip surface of the imaging lens and that there is a reasonable installation precision.

8. Technical Specifications

The conditions for technical specifications are as follows unless otherwise specified in each section.

<Conditions>

Temperature and humidity : Room temperature, room humidity

Ambient light : 500 lx

Background : White

Power supply voltage : 3.3 V

Test PCS : PCS 0.9

PCS = (Reflectance of white bar - Reflectance of black bar) / Reflectance of white bar

Reading test : Accept 4 successful reading within 5 consecutive attempts.
Each successful reading is in 0.25 seconds or less.

8.1. Depth of Field

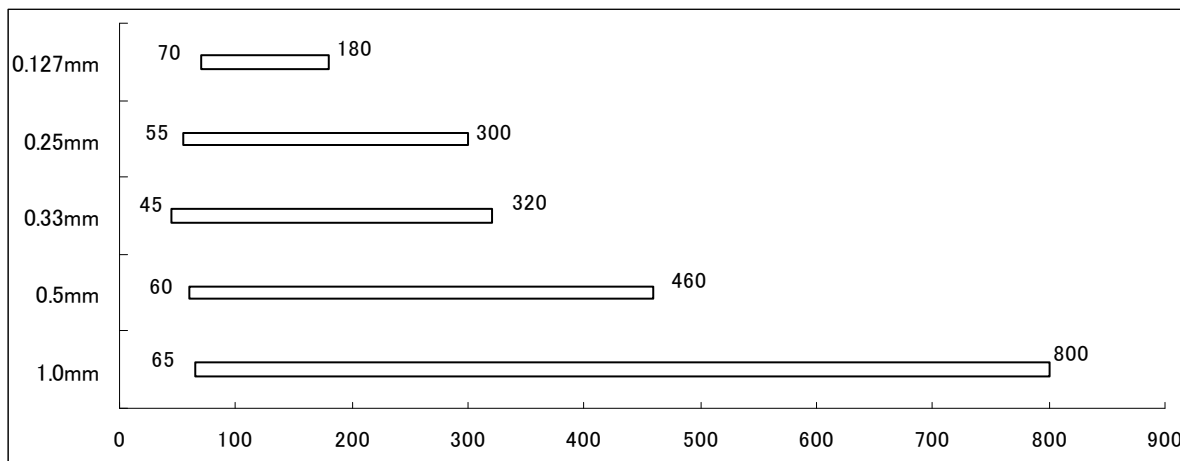

*The decoding range is from the edge of the imaging lens.

<Conditions>

Resolution	Symbology	PCS	Quiet Zone	No. of Digits
1.0 mm	Code 39	0.9	20 mm	1
0.5 mm	Code 39	0.9	10 mm	4
0.33 mm	EAN-13	0.9	10 mm	13
0.25 mm	Code 39	0.9	5 mm	9
0.127 mm	Code 39	0.9	7 mm	4

Bar Code Sample : Optoelectronics Test Chart, N/W ratio = 1 : 2.5

Angle : $\alpha = 0^\circ$ $\beta = 15^\circ$ $\gamma = 0^\circ$

Curvature : $R = \infty$

8.2. Pitch, Skew and Tilt

Pitch : $\alpha \cong \pm 50^\circ$
 Skew : $\beta \cong \pm 65^\circ$
 Tilt : $\gamma \cong \pm 25^\circ$

<Conditions>

Bar code : Optoelectronics Test Sample
 Distance : 110 mm from the edge of the scan engine
 PCS 0.9, Resolution 0.33 mm, EAN-13, Quiet Zone 15 mm
 Angle : Pitch and Tilt angles calculated with Skew angle $\beta = +15$ degree
 Curvature : $R = \infty$

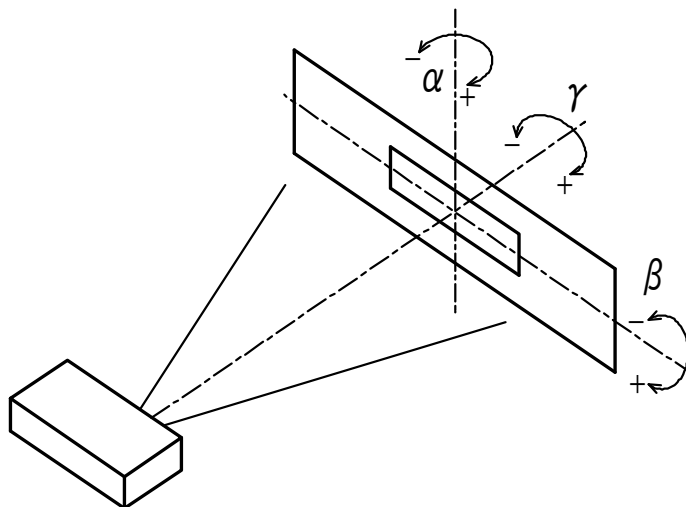

Figure 6: Pitch, Skew and Tilt

8.3. Curvature

JAN-8 : $R \geq 15$ mm

<Conditions>

Bar code : Optoelectronics Test Sample
 PCS 0.9, Resolution 0.26 mm, EAN-8, Quiet Zone 10 mm
 Distance : 110 mm from the edge of the scan engine
 Angle : Skew angle $\beta = +15^\circ$

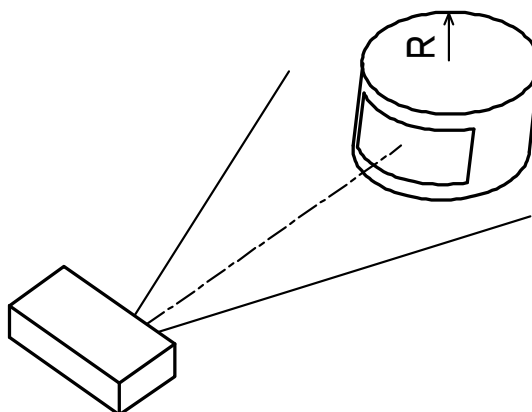

Figure 7: Curvature

9. Environmental Specifications

9.1. Temperature

Operating temperature	: -20 ~ 60 °C
Storage temperature	: -40 ~ 70 °C

9.2. Humidity

Operating humidity	: 5 ~ 90% RH (no condensation, no frost)
Storage humidity	: 5 ~ 90% RH (no condensation, no frost)

9.3. Ambient Light Immunity

Decoding performance is guaranteed when the range of illumination on a bar code surface is between zero and the following values:

Incandescent light	: 4,000 lx
Fluorescent light	: 4,000 lx
Sunlight	: 100,000 lx

* Be sure that direct light or specular reflection from the light source does not enter the light receiving area of the scan engine.

9.4. Electrostatic Noise

There shall be no abnormalities in the output signals when sinusoidal electrical noise (50 Hz to 100 kHz, smaller than 0.1 Vpp) is added to the power supply line.

9.5. Vibration Strength

There shall be no sign of malfunction after the following vibration test.

Vibration test: Increase the frequency of the vibration from 12 Hz to 200 Hz at an accelerated velocity of 32.3 m/s^2 (3.3 G) for 10 minutes per cycle. Repeat this for 2 hours in X-direction, 2 hours in Y-direction and 4 hours in Z-direction.

9.6. Drop Impact Strength

There shall be no sign of malfunction after the following drop test.

Drop test: Fix the scan engine in a specific dummy case and drop it 10 times in total, at top, bottom, front, back, left, right, top-left, top-right, bottom-left and bottom-right faces, from a height of 180 cm onto a concrete floor.

10. Regulatory Compliance

LED Safety: IEC 62471-1:2006 Exempt_Group

11. RoHS

The MDC-200 is compliant with RoHS.

RoHS: The restriction of the use of certain hazardous substances in electrical and electronic equipment, 2011/65/EU

12. Reliability

MTBF (Mean Time Between Failures) 100,000 hours

* It is calculated based on standard operation of the product within the recommended temperature range and without extreme electronic or mechanical shock.

13. Precautions

- All work-benches, tools, measuring instruments and any part of human body which have come into contact with MDC-200 must undergo preliminary antistatic treatments.
- Do not touch the optical and electrical components. If the MDC-200 needs to be picked up, hold it on the camera body.
- Avoid handling MDC-200 in a dusty area. In case dust gets on MDC-200, gently blow it off with dry air. Direct contact of swabs and such on its optical part may cause deterioration of its performance.

14. Packaging Specifications

14.1. Packaging

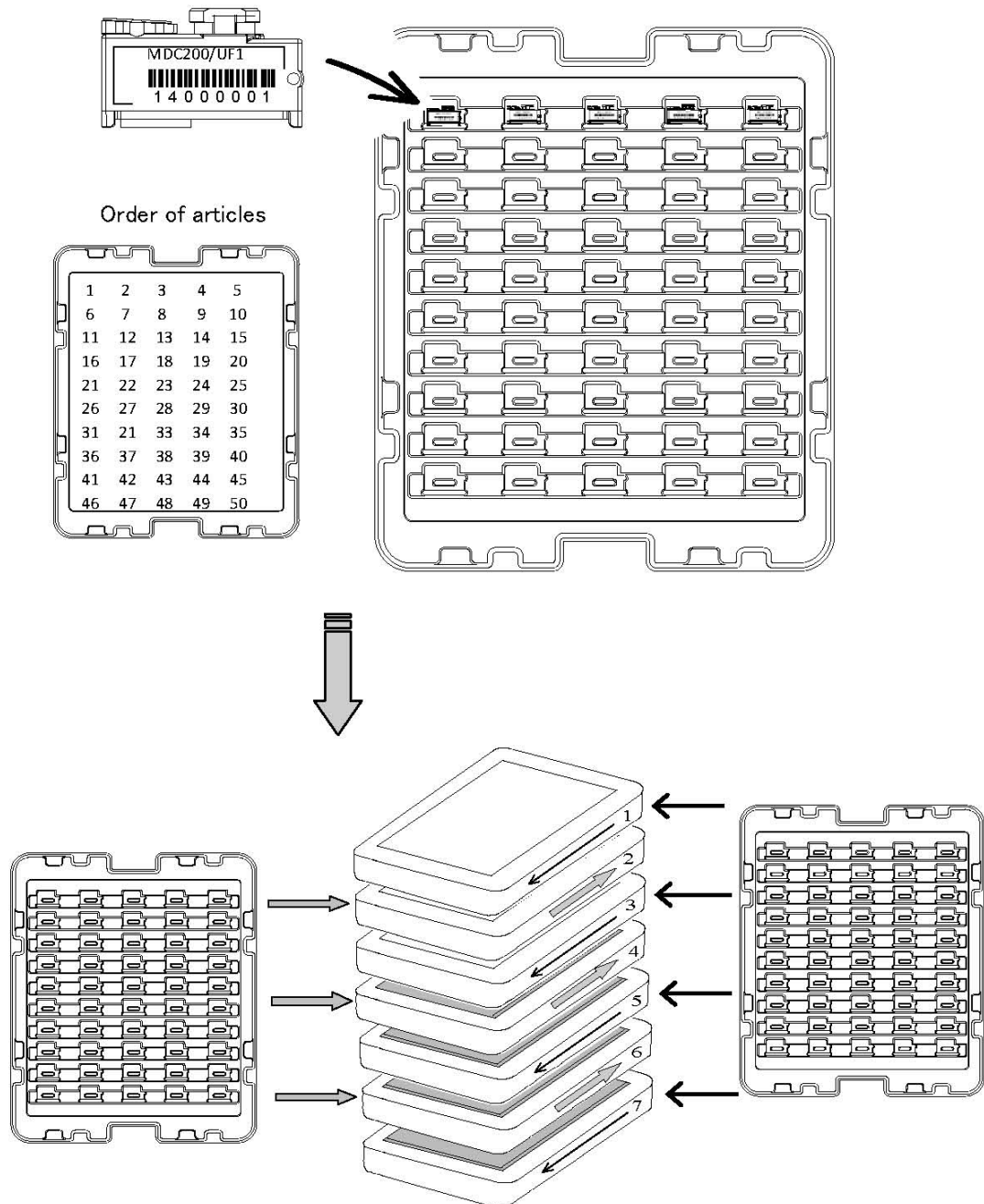

- 50 pieces in one tray
- 7 trays in one package (total 350 pieces for one package)

Figure 8: Packaging 1

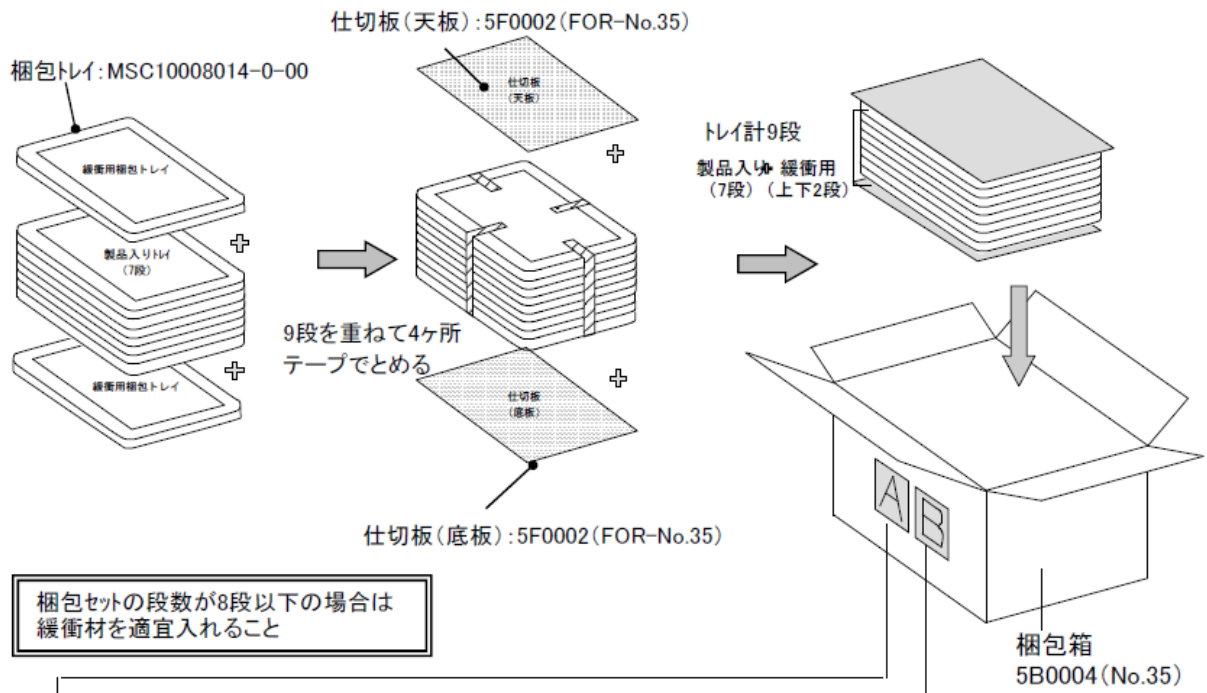

A : Barcode Serial Label for Packaging Box:
Stick the labels on both front and back side of the box.

B : Missing Serial Number Label:
Attach this label when there are more than 3 labels of which
serial numbers are out of order (not in a correct sequence).

(3C0006)

UNIVERSAL C/No. $\triangle\triangle$
MADE IN $\blacktriangle\blacktriangle\blacktriangle\blacktriangle$

Product MDC-200-CMOS

PO# $*\triangle\triangle\triangle\triangle-\triangle\triangle*$

Spec#JPN $*U F 1 M D C 2 0 0 C *$

Spec#EUR $*1 5 6 2 7 *$

Q'ty $*\triangle\triangle*$ S/N (from) $*14000001*$

$\triangle\triangle/\triangle\triangle\triangle$ S/N (to) $*140\blacktriangle\blacktriangle\blacktriangle*$

Missing Serial Number	Missing Q'ty \triangle
1	$*14\triangle\triangle\triangle\triangle\triangle*$
2	$*14\triangle\triangle\triangle\triangle\triangle*$

ROM-Ver. TC06J $\triangle\triangle$

Shipping Date 20 $\triangle\triangle$ / $\triangle\triangle$ / $\triangle\triangle$

Ro

OPTOELECTRONICS CO., LTD.

(3C0007)

UNIVERSAL C/No. $\triangle\triangle$
MADE IN $\blacktriangle\blacktriangle\blacktriangle\blacktriangle$

Missing Serial Number	Missing Q'ty $\triangle\triangle$
3	$*\triangle\triangle\triangle\triangle\triangle\triangle\triangle\triangle*$
4	$*\triangle\triangle\triangle\triangle\triangle\triangle\triangle\triangle*$
5	$*\triangle\triangle\triangle\triangle\triangle\triangle\triangle\triangle*$
6	$*\triangle\triangle\triangle\triangle\triangle\triangle\triangle\triangle*$
7	$*\triangle\triangle\triangle\triangle\triangle\triangle\triangle\triangle*$
8	$*\triangle\triangle\triangle\triangle\triangle\triangle\triangle\triangle*$
9	$*\triangle\triangle\triangle\triangle\triangle\triangle\triangle\triangle*$
10	$*\triangle\triangle\triangle\triangle\triangle\triangle\triangle\triangle*$
11	$*\triangle\triangle\triangle\triangle\triangle\triangle\triangle\triangle*$
12	$*\triangle\triangle\triangle\triangle\triangle\triangle\triangle\triangle*$

OPTOELECTRONICS CO., LTD.

【原産国表示】 ~country of origin~

中国生産 (produced in China) =MADE IN CHINA 日本生産 (produced in Japan) =MADE IN JAPAN

Figure 9: Packaging 2

14.2. Package Size

355 × 290 × 185 (WDH mm)

* 'Ro mark' on the trays or boxes for the product indicates that the product is RoHS compliant.

15. Serial Label

The following label with serial number is attached to the product.

Top : Product name
Middle : Bar code (Code 128, Resolution 0.2, N/W 2.5)
Bottom : Serial number

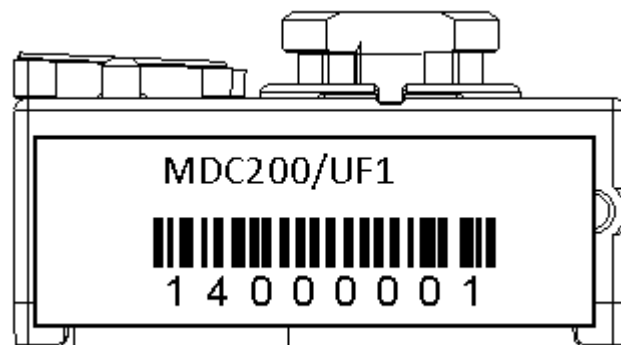

Figure 10: Serial Label

16. Mechanical Drawing

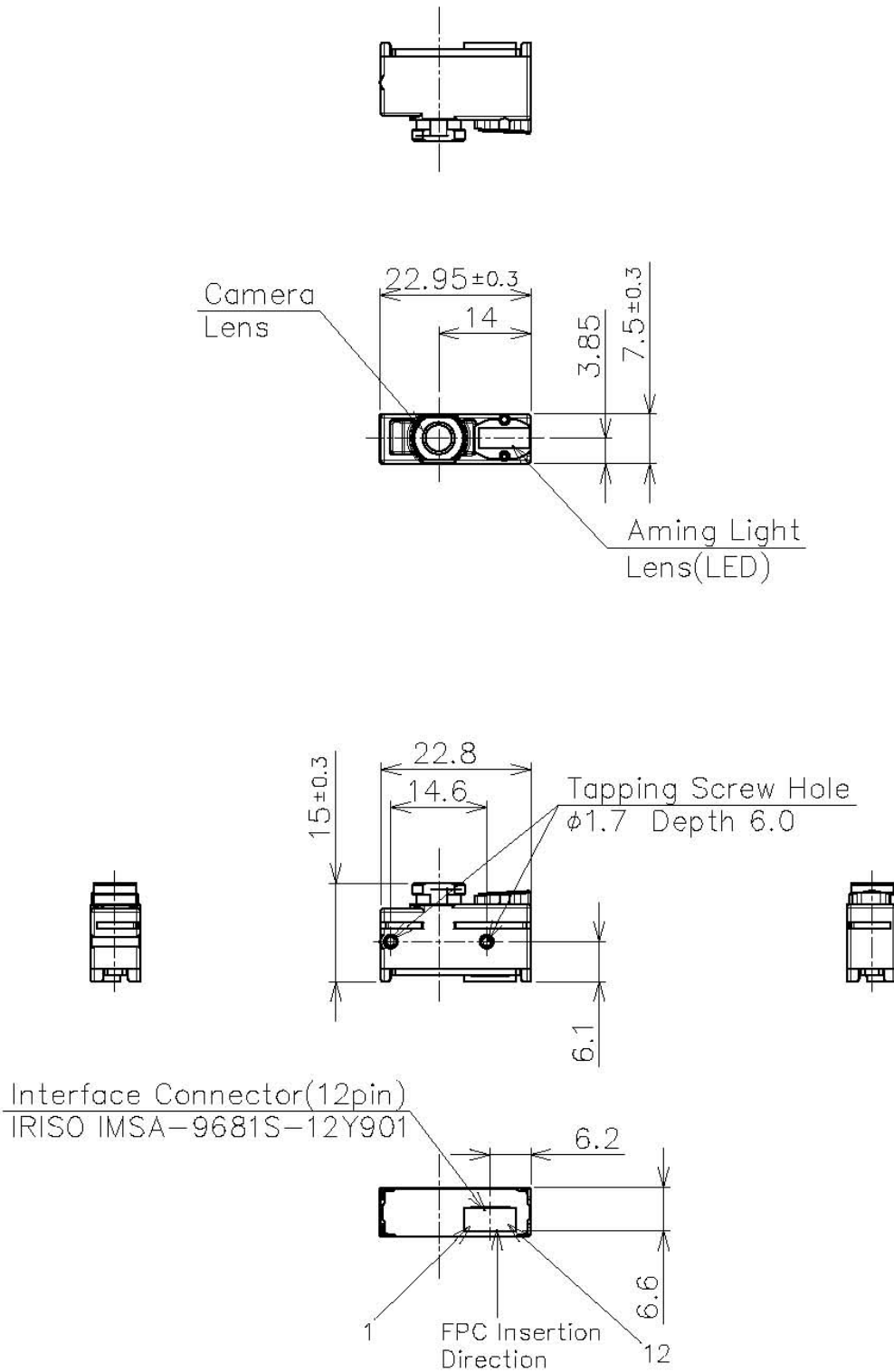

Figure 11: Mechanical Drawing